

burton

Luxo Medical Products



SUPER EXAM 50™

PERFORMANCE RELIABILITY VALUE



Introducing the most
positionable, high intensity
examination light
on the market.

The Right Light

TASK & EXAMINATION

SUPER EXAM 50™

Burton's Super Exam 50™ delivers best-in-class intensity, color temperature and CRI – all on a highly-positionable K-arm.

Super Exam 50™ is designed especially for demanding viewing conditions that require exceptionally good light. Ideal for medical examination and minor procedures, it has widespread applications throughout healthcare. Delivering higher illumination in a limited area, Super Exam 50™ is ideal for obstetrics, gynecology and emergency rooms.



Boasting a highly flexible, self-balancing arm system, the Super Exam 50™ is the most positionable examination light on the market. The horizontal and vertical movement is the best in its class. Super Exam 50™ uses the latest halogen technology for maximum light output and color rendering. A dual lens optical system collects and concentrates the light in a precise beam. Super Exam 50™ is suitable for ceiling, wall, floor, rail and table mounting.



Drift-free K-arm provides better positioning than goosenecks



K-ARM TECHNOLOGY

Medical products are used in a dynamic environment and need a great level of flexibility. Friction-based arms with tightening screws make movement a problem. If you loosen a friction screw too much, the arm will collapse! That's why Burton's Super Exam 50™ uses a unique, self-balancing K-Arm. No other arm in the market offers this kind of extensive reach. Internal springs ensure smooth, easy positioning, and the arm will stay in the right position without drifting.

Specially designed light head reduces surface temperature



Unique dual lens technology produces greater light intensity than competitive models



SUPER EXAM 50™ FEATURES:

- > High intensity of 45,750 Lux at 24"
 - > 3800° K color temperature
 - > CRI (Color Rendering Index) of 99
 - > 115/120 and 230/240 volt models available
 - > Drift-free K-arm with 42" arm range
 - > 50W MR-16 bulb with 4000-hr life
- > Floorstand, Wall, Rail Mount, Ceiling Mount and Table Mount configurations
 - > Rail mount bracket that can be attached to a bed rail or wall rail
 - > 5-year warranty
 - > IEC 60601-1/ 60601-2-41 Certified
 - > CE approved

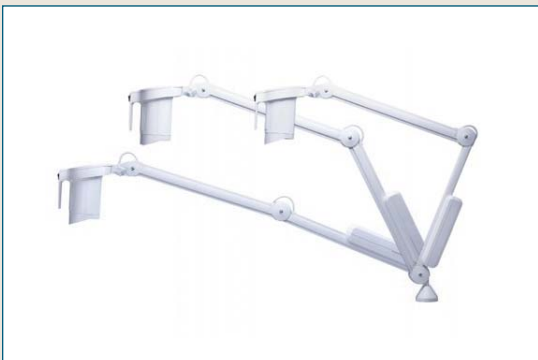

ARMS FOR HORIZONTAL MOVEMENT

Designed for maximum movement in the horizontal plane. Typical applications: Floor stand, table mounted.



ARMS FOR VERTICAL MOVEMENT

Designed for maximum vertical movement. This type of arm has more vertical movement than arms found on large operating lights. The arm will always tilt forward to avoid collisions with the wall. Typical applications: Wall mounted, ceiling mounted, rail mounted.

Compare and you will choose
Burton's SUPER EXAM 50™



SUPER EXAM 50™ COMPETITIVE DATA

	BURTON SUPER EXAM 50™	Waldmann Halux 50	Welch Allyn LS 150
Intensity @ 24" (Lux)	45,750	30,000*	6,160
Color temp. (°K)	3,800	4,700	4,700
CRI	99	95*	95*
Bulb Type	MR-16	MR-16	MR-16
Wattage (W)	50	50	50
Advertised Bulb Life (Hrs.)	4,000	3,000	3,000
Arm Configuration	K-arm	Gooseneck or friction arm	Gooseneck
Arm Range	42"	31.5" or 37"	31"

* Estimated or measured



SUPER EXAM 50™ RANGE OF MOTION

SUPER EXAM 50™ CEILING

(arm movement same as for wall and rail mounts)

SUPER EXAM 50™ FLOOR

(arm movement same as for table mount)

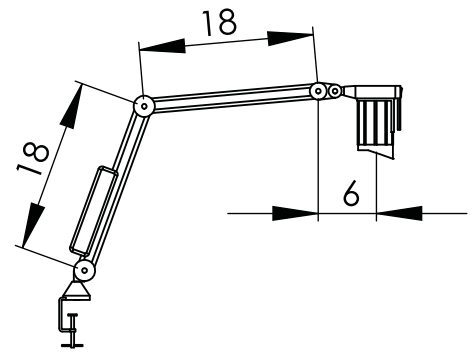
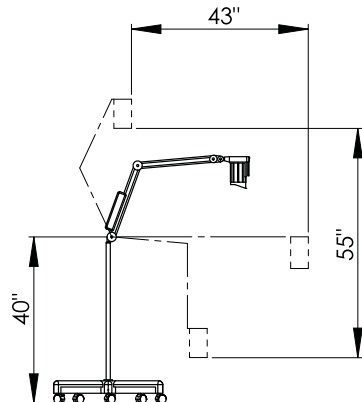
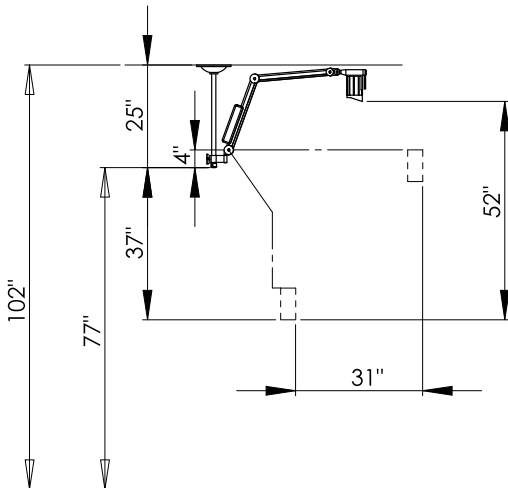

MODELS

115/120V	230/240V	
SE50FL	SE51FL	Super Exam 50™ Floorstand
SE50W	SE51W	Super Exam 50™ Wall
SE50R	SE51R	Super Exam 50™ Rail Mount
SE50SC	SE51SC	Super Exam 50™ Ceiling Mount
SE50T	SE51T	Super Exam 50™ Table Mount

ACCESSORIES

4000061PK MR-16 Replacement Bulbs (3 bulbs)



Luxo Medical Products

BURTON MEDICAL

An ISO Certified Company
21100 Lassen Street
Chatsworth, CA 91311
USA

Phone: 800-444-9909, 818-701-8700

Fax: 800-765-1770, 818-701-8725

www.burtonmedical.com

The Right Light